



AV490
SKID STEER LOADERS

**TOUGH
AGILE
FUEL SAVER**

JOYSTICK DRIVE



THE BEST ALL ROUNDER

Interchangeable attachments



Sweeper attachment



Backhoe attachment



Concrete mixer attachment



Save 25% more fuel



Forklift attachment



RUN ALL DAY

Forget your Fuel Meter

- Fan for Radiator and cooler are directly mounted on Engine which improves efficiency.
- It saves power resulting in lower fuel consumption.

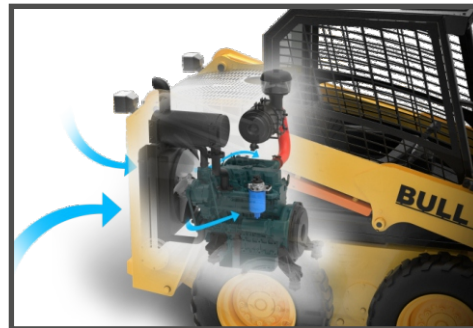

Easy Serviceability

- Pump is directly coupled to engine via reliable flexible coupling.
- Maintenance free and trouble free operation.
- Pre Cleaner provided for dusty environment.

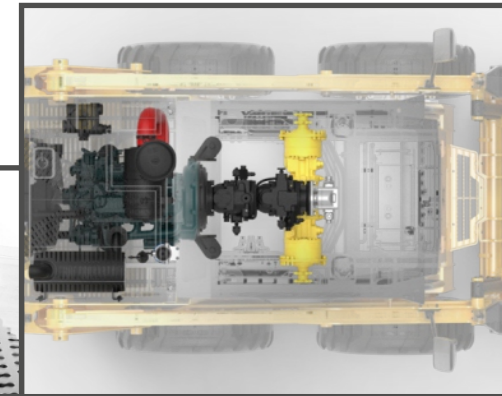
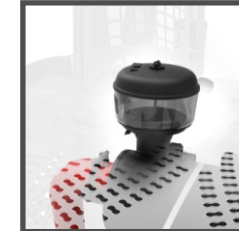

WE GIVE YOU EYES BEHIND

Rear Camera



- Rear View Camera gives better visibility, Reduces Blind spots.



FUN IN TOUGH WORKS

Inbuilt LED light & Music player



ADDITIONAL FOOT ACCELERATOR

Foot accelerator for optimal speed management

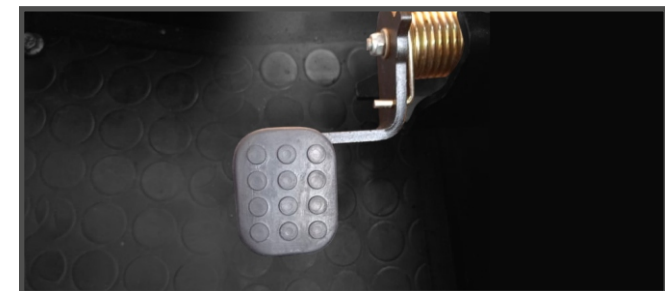



ALL THE TECH IN TOUCH

Touch Screen Infotainment

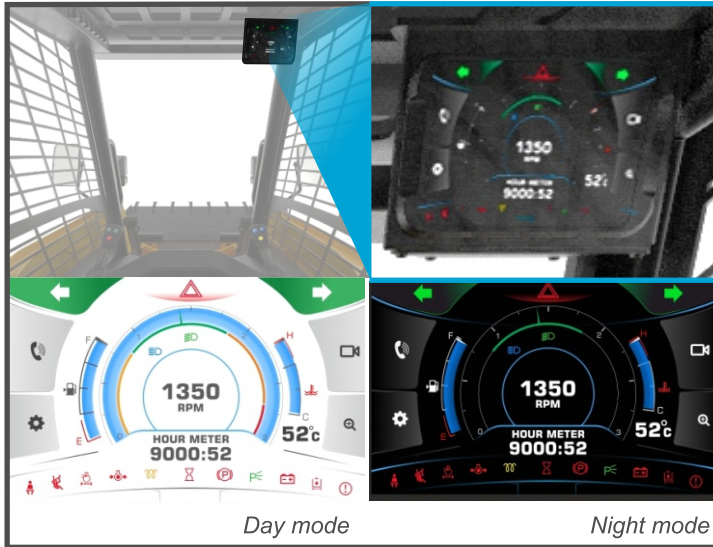

- TFT Resistive touch screen, able to operate even with oily hands.
- Day and Night mode for better visibility.
- Auto Brightness adjustment feature.
- Rear View camera display.

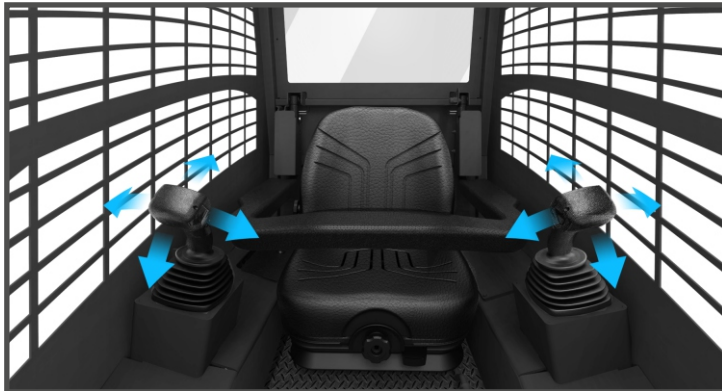

OPERATOR SAFETY LOCK

When safety bar is raised, travel and implement hydraulic system will be disabled. Parking brake will also be engaged automatically



PILOT OPERATED JOYSTICKS

Effortless operation leads to less fatigue and increased operator efficiency



SUSPENSION SEAT

Standard feature for better operator comfort

Machine Rating

Rated Operating Capacity	Kg	655
Tipping Load	Kg	1310
Pump Capacity	Lpm	60.0
System Relief Pressure	MPa	23.0
Max Travel Speed	Km/hr	14.0

Engine

Model	KUBOTA	
Fuel Type	Diesel	
Cooling	Liquid	
Max.power @ 2700 rpm	36.5kW (49.5 HP)	
Max.Torque @ 1600 rpm	Nm	158.6
No.of. Cylinders	No.	4

Weights

Operating Weight	Kg	2610
------------------	----	------

Electrical

Battery	V	12
Alternator	Amps	90

Capacity

Fuel	L	48
Engine Oil	L	9.5
Coolant	L	7.2
Hydraulic System (Including Tank)	L	65
LH Chain Case	L	10
RH Chain Case	L	10

Drive System

Transmission: Hydrostatic drive with hydraulic pilot operated variable displacement tandem pump with heavy duty radial piston bidirectional motor

Type Of Drive: 4WD - Chain Drive

Control

Vehicle Steering	Skid steering, Controlled by a left hand side Single Joystick
Loader Hydraulic Tilt And Lift	Single Joystick on right hand side
Front Auxiliary (std)	Electrical switch on right hand side Joystick

Tyre

10X16.5-10 PR Heavy/Medium Duty, Solid Tyre

Attachments

Backhoe, Sweeper, Pallet Fork, Concrete mixer etc.,

Optional

Self Levelling Valve, Anti stalling feature, AC Cabin, Aux. Hydraulics

DIMENSIONS

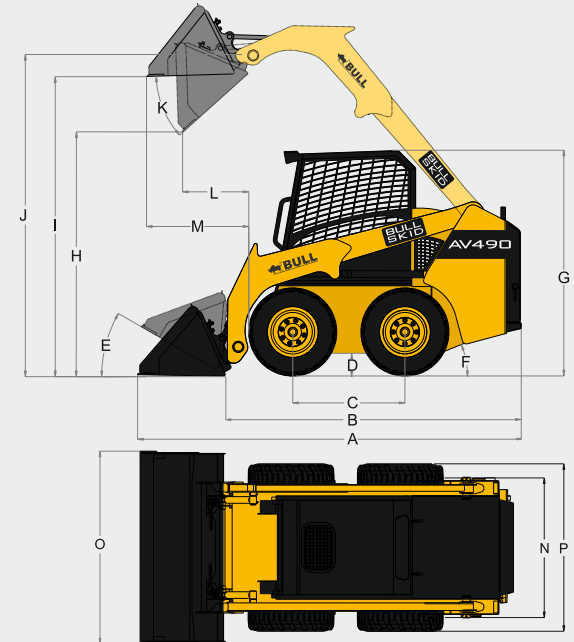

A	Over All Length	3282 mm	10'-9.2"
B	Length Without Attachment	2511 mm	8'-2.8"
C	Wheel Base	980 mm	3'-2.6"
D	Ground Clearance	204 mm	8.03"
E	Roll Back Angle	30°	
F	Departure Angle	27°	
G	Over All Height	1970 mm	6'-5.5"
H	Dump Height @ 40°	2160 mm	7'-1"
I	Load Over Height	2646 mm	8'-8.2"
J	Pin Height	2813 mm	9'-2.7"
K	Dump Angle	42°	
L	Dump Reach	588 mm	1'-11"
M	Max Reach at Full Height	910 mm	2'-11.8"
N	Track Width with spec tyre	1245 mm	4'-1"
O	Bucket Width	1580 mm	5'-2.2"
P	Width Over Tyres-Standard	1500 mm	4'-11"
	Turning Radius		
	Bucket	2039 mm	6'-8.2"
	Tyre	1125 mm	3'- 8.3"
	Rear Chassis	1426 mm	4'-8.1"

*All specifications are subjected to change by BULL without prior notice.

SMART KID

New Class of Backhoe Loader

JOYSTICK DRIVE





Widest Range Of Earth Moving Machines



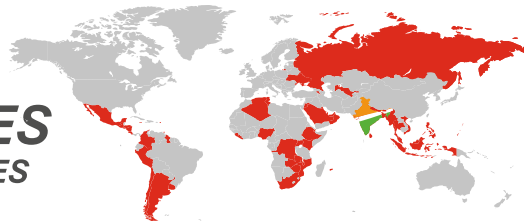

NOW IN
59+ COUNTRIES
150+ SERVICE CENTRES



 +91 98422 87770

 sales@bullmachine.com

exports@bullmachine.com

   / bullmachines

Dealer

www.bullindia.com